

Фрезер СМТ за дърво профилен прав, без лагер, с видиева пластина ф 16х60/110 мм, ф 12 мм, 177 НВ

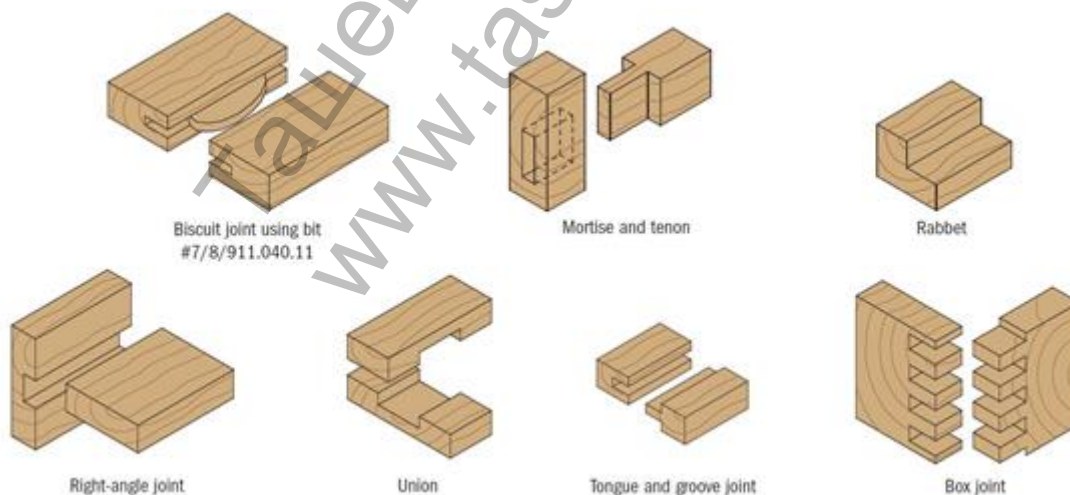
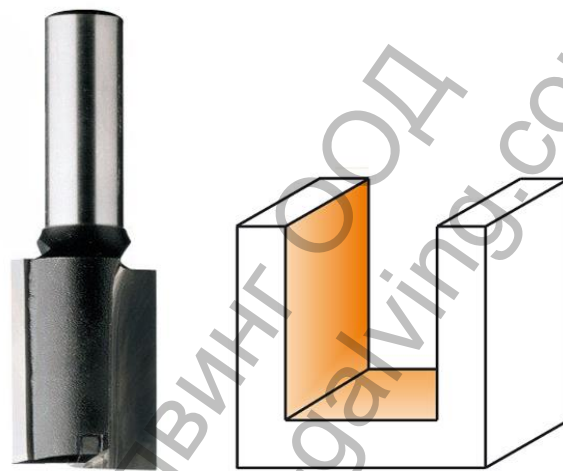

These industrial straight bits are made a kind of stainless steel specifically created to support hard work on route machines and CNC routers. The cutting plunging edge will allows you to execute any kind of drilling and trimming jobs on soft and hardwood, wood composites and also plastic and laminated materials.

Application

Used for drilling, grooving or jointing solid wood and

wood composites. Can be used on machining centres, CNC routers and hand-held routers equipped with chucks or adaptors.



Tungsten carbide

Tipped



Solid tungsten carbide



Two cutting edges



Right-hand rotation



Tool with plunging

Capacity

D mm	I mm	L mm	ORDER NO. S=Ø8mm	D mm	I mm	L mm	ORDER NO. S=Ø12mm
• 3	10	55	174.030.11	10	35	90	177.100.11
• 4	10	55	174.040.11	12	35	90	177.120.11
• 5	12	55	174.050.11	12	50	100	177.121.11
• 6	14	55	174.060.11	14	35	90	177.140.11
• 7	20	55	174.070.11	16	35	90	177.160.11
8	20	55	174.080.11	16	60	110	177.161.11
8	30	70	174.081.11	18	35	90	177.180.11
8	40	90	174.082.11	18	60	110	177.181.11
9	20	55	174.090.11	20	35	90	177.200.11
10	20	60	174.100.11	22	35	90	177.220.11
10	30	70	174.102.11	24	35	90	177.240.11
10	40	90	174.101.11	25	35	90	177.250.11
11	20	60	174.110.11	26	35	90	177.260.11
12	20	60	174.120.11	28	35	90	177.280.11
12	30	70	174.122.11	30	35	90	177.300.11
12	40	90	174.121.11	35	35	90	177.350.11
13	20	60	174.130.11				
14	20	60	174.140.11				
14	30	70	174.142.11				
14	40	90	174.141.11				
15	20	60	174.150.11				
16	20	70	174.160.11				
16	30	70	174.162.11				
16	40	90	174.161.11				
18	20	70	174.180.11				
18	30	70	174.181.11				
18	40	80	174.182.11				
19	20	70	174.190.11				
20	20	70	174.200.11				
20	30	70	174.201.11				
20	40	90	174.202.11				
22	20	70	174.220.11				
22	30	70	174.221.11				
22	40	90	174.222.11				
24	20	70	174.240.11				
24	30	70	174.241.11				
24	40	90	174.242.11				
25	20	70	174.250.11				
26	20	70	174.260.11				
26	30	70	174.261.11				
28	20	70	174.280.11				
28	30	70	174.281.11				
29	20	70	174.290.11				
30	20	70	174.300.11				

Продукт: [Фрезер CMT за дърво профилен прав, без лагер, с видиева пластина ф 16x60/110 мм, ф 12 мм, 177 HW](#)

Категория: [Консумативи за фрези и оберфрези](#)

Бранд: [CMT](#)

Категория бранд: [Фрезер CMT](#)